

Prosilica GT 5400



- -20° C to +65° C (ambient temperature)
- PoE
- IEEE 1588 PTP
- Trigger over Ethernet
- Auto iris

Engineered for every environment

High-resolution cameras for demanding applications

Prosilica GT 5400 with Sony IMX387 runs 7.1 frames per second at 16.9 MP resolution.

The rugged housing optimized for heat dissipation makes Prosilica GT the ideal solution for harsh environments. The various lens control options allow constant adjustment of the image brightness to changing light conditions. Offering resolutions of up to 31 megapixels, they are ideal for high-definition imaging applications with demanding requirements of robustness and design-in flexibility.

Easy software integration with Allied Vision's [Vimba Suite](#) and compatibility to the most popular [third party image-processing libraries](#).

See the [Modular Concept](#) for lens mount, housing variants, optical filters, case design, and other modular options. See the [Customization and OEM Solutions](#) webpage for additional options.

Specifications

Prosilica GT 5400	
Interface	IEEE 802.3 1000BASE-T, IEEE 802.3af (PoE)
Resolution	5472 (H) × 3084 (V)
Sensor	Sony IMX387
Sensor type	CMOS
Shutter mode	Global shutter
Sensor size	Type 4/3

Prosilica GT 5400

Pixel size 3.45 μm \times 3.45 μm

Lens mounts (available) F-Mount

Max. frame rate at full resolution 7.14 fps

ADC 12 Bit

Image buffer (RAM) 128 MByte

Imaging performance

Imaging performance data is based on the evaluation methods in the EMVA 1288 Release 3.1 standard for characterization of image sensors and cameras. Measurements are typical values for monochrome models measured at full resolution without optical filter.

Quantum efficiency at 529 nm 64 %

Temporal dark noise 2.3 e^-

Saturation capacity 10300 e^-

Dynamic range 72 dB

Absolute sensitivity threshold 2.7 e^-

Output

Bit depth 12 Bit

Monochrome pixel formats Mono8, Mono12Packed, Mono12

YUV color pixel formats YUV411Packed, YUV422Packed, YUV444Packed

RGB color pixel formats RGB8Packed, BGR8Packed

Raw pixel formats BayerRG8, BayerRG12, BayerRG12Packed

General purpose inputs/outputs (GPIOs)

TTL I/Os 1 input, 2 outputs

Opto-isolated I/Os 1 input, 2 outputs

RS232 1

Operating conditions/dimensions

Operating temperature -20 $^{\circ}\text{C}$ to +50 $^{\circ}\text{C}$ housing (without condensation)

Power requirements (DC) 7 to 25 VDC AUX or IEEE 802.3at Type 1 PoE

Power consumption External power: 5.2 W at 12 VDC | Power over Ethernet: 6.4 W

Mass 372 g

Body dimensions (L \times W \times H in mm) 96 \times 66 \times 53.3 (including connectors)

Prosilica GT 5400

Regulations

CE: 2014/30/EU (EMC), 2011/65/EU, including amendment 2015/863/EU (RoHS); FCC Class A; CAN ICES-3 (A)

Quantum efficiency

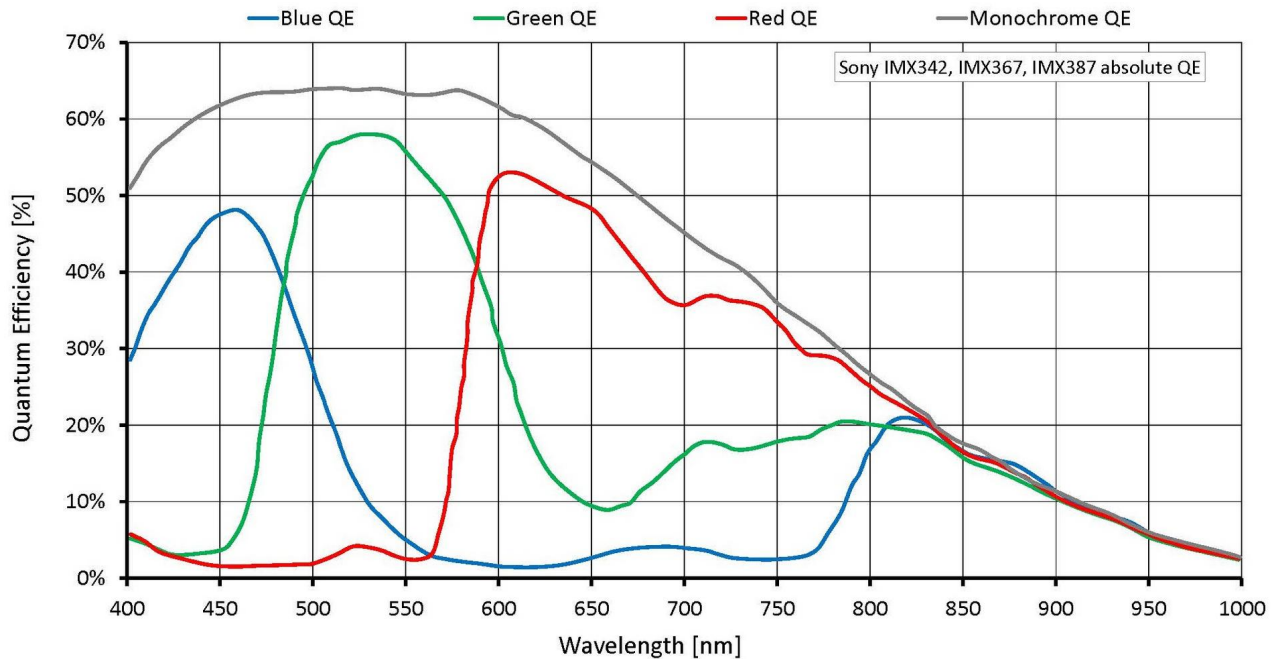

Features

Image control: Auto

- Auto exposure
- Auto gain
- Auto white balance (color models)

Image control: Other

- Binning
- Black level
- Color transformation (incl. hue, saturation; color models)

- Decimation
- DPC (defect pixel correction)
- Gamma
- LUT (look-up table)
- Reverse X/Y
- ROI (region of interest)

Camera control

- Acquisition frame rate
- Auto iris
- Bandwidth control
- EF Mount lens control
- Event channel
- Firmware update in the field
- I/O and trigger control
- Image chunk data
- Stream hold
- Temperature monitoring
- ToE (trigger over Ethernet, action commands)
- User sets

Technical drawing

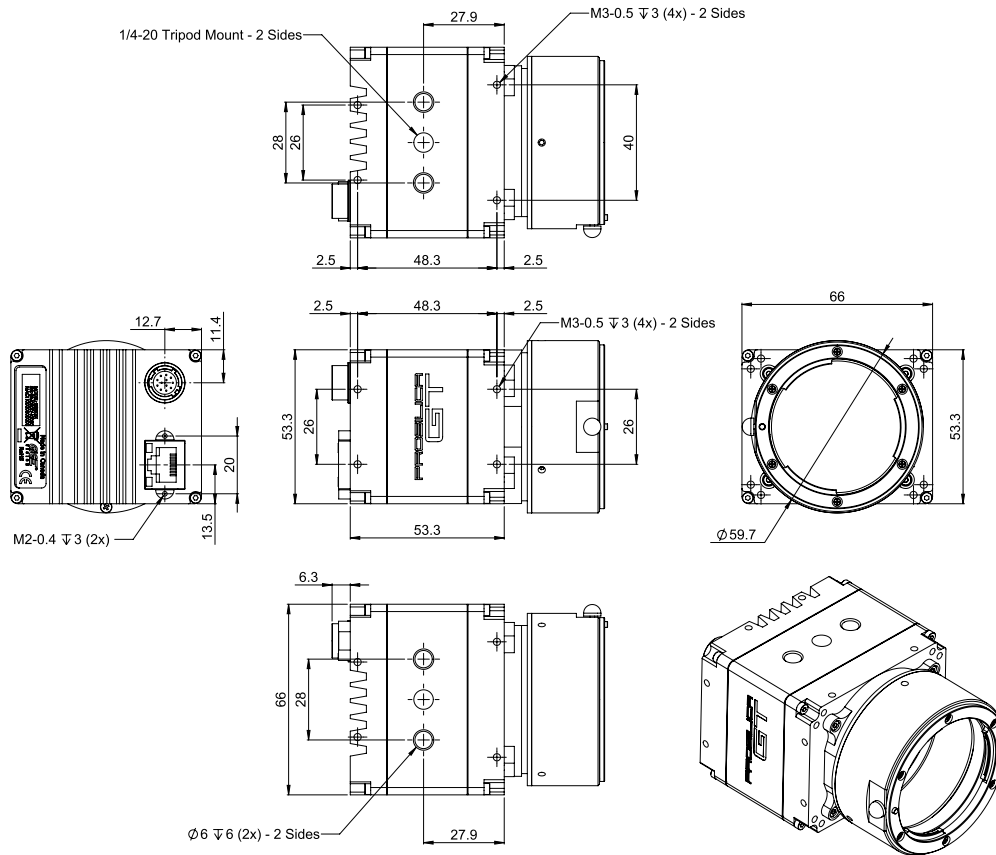

Applications

Prosilica GT5400 is ideal for a wide range of applications including:

- Industrial inspection including display inspection, surface inspection, semiconductor packaging inspection, print inspection, 2D/3D metrology, laser beam profiling, and automated optical inspection
- Outdoor imaging applications including railway inspection, aerial imaging, traffic and transportation, surveillance, and defense
- Medical and life sciences applications including lab and biomedical imaging, pharma and cosmetic inspection, track and trace applications
- Archival imaging of documents and digitization of film