

# Prosilica GT 1600

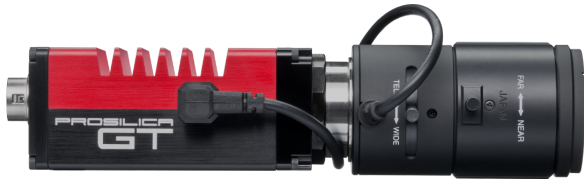

- -20° C to +65° C (ambient temperature)
- PoE
- IEEE 1588 PTP
- Trigger over Ethernet
- Auto iris

Engineered for every environment

## High-resolution cameras for demanding applications

Prosilica GT 1600 with Sony ICX274 runs 25.8 frames per second at 2.0 MP resolution.

The rugged housing optimized for heat dissipation makes Prosilica GT the ideal solution for harsh environments. The various lens control options allow constant adjustment of the image brightness to changing light conditions. Offering resolutions of up to 31 megapixels, they are ideal for high-definition imaging applications with demanding requirements of robustness and design-in flexibility.

Easy software integration with Allied Vision's [Vimba Suite](#) and compatibility to the most popular [third party image-processing libraries](#).

See the [Modular Concept](#) for lens mount, housing variants, optical filters, case design, and other modular options. See the [Customization and OEM Solutions](#) webpage for additional options.

## Specifications

| Prosilica GT 1600 |   |
|-------------------|---|
| Interface         | IEEE 802.3 1000BASE-T, IEEE 802.3af (PoE) |
| Resolution        | 1620 (H) × 1220 (V)                       |
| Sensor            | Sony ICX274                               |
| Sensor type       | CCD Progressive                           |
| Shutter mode      | Global shutter                            |
| Sensor size       | Type 1/1.8                                |

## Prosilica GT 1600

|                                    |  |
|------------------------------------|--|
| Pixel size                         | 4.4 $\mu\text{m}$ $\times$ 4.4 $\mu\text{m}$ |
| Lens mounts (available)            | C-Mount, CS-Mount, F-Mount, M42-Mount        |
| Max. frame rate at full resolution | 25.8 fps                                     |
| ADC                                | 14 Bit                                       |
| Image buffer (RAM)                 | 128 MByte                                    |

## Imaging performance

Imaging performance data is based on the evaluation methods in the EMVA 1288 Release 3.1 standard for characterization of image sensors and cameras. Measurements are typical values for monochrome models measured at full resolution without optical filter.

|                                |                   |
|--------------------------------|-------------------|
| Quantum efficiency at 529 nm   | 47 %              |
| Temporal dark noise            | 8.8 $\text{e}^-$  |
| Saturation capacity            | 4900 $\text{e}^-$ |
| Dynamic range                  | 54.3 dB           |
| Absolute sensitivity threshold | 9.3 $\text{e}^-$  |

## Output

|                          |  |
|--------------------------|--|
| Bit depth                | 12/14 Bit                                |
| Monochrome pixel formats | Mono8, Mono12, Mono12Packed, Mono14      |
| YUV color pixel formats  | YUV411Packed, YUV422Packed, YUV444Packed |
| RGB color pixel formats  | RGB8Packed, BGR8Packed                   |
| Raw pixel formats        | BayerRG8, BayerRG12, BayerRG12Packed     |

## General purpose inputs/outputs (GPIOs)

|                    |                    |
|--------------------|--------------------|
| TTL I/Os           | 1 input, 2 outputs |
| Opto-isolated I/Os | 1 input, 2 outputs |
| RS232              | 1                  |

## Operating conditions/dimensions

|   |   |
|---|---|
| Operating temperature                           | -20 $^{\circ}\text{C}$ to +65 $^{\circ}\text{C}$ ambient (without condensation) |
| Power requirements (DC)                         | 7 to 25 VDC AUX or 802.3at Type 1 PoE   |
| Power consumption                               | 3.3 W at 12 VDC; 4.0 W PoE  |
| Mass  | 211 g   |
| Body dimensions (L $\times$ W $\times$ H in mm) | 86 $\times$ 53.3 $\times$ 33 (including connectors)                             |

## Prosilica GT 1600

### Regulations

CE: 2014/30/EU (EMC), 2011/65/EU, including amendment 2015/863/EU (RoHS); FCC Class A; CAN ICES-3 (A)

## Quantum efficiency

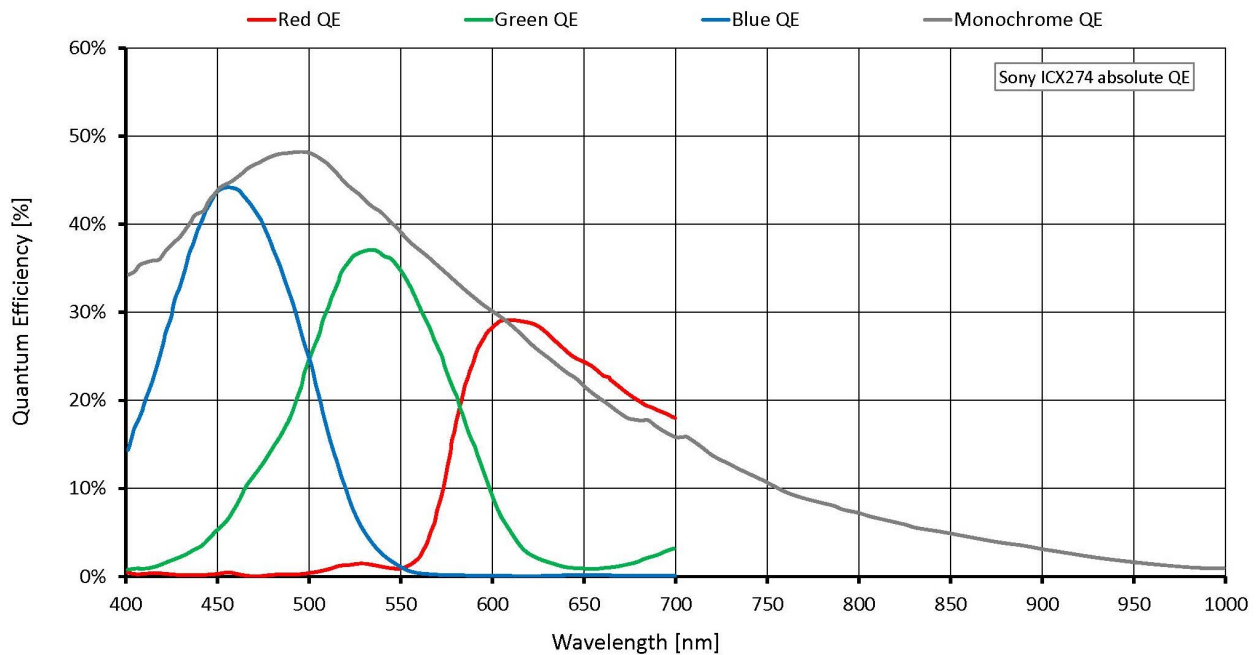

## Features

### Image control: Auto

- Auto exposure
- Auto gain
- Auto white balance (color models)

### Image control: Other

- Binning
- Color transformation (incl. hue, saturation; color models)
- Decimation

- Gamma
- LUT (look-up table)
- ROI (region of interest)

## Camera control

- Acquisition frame rate
- Auto iris
- Bandwidth control
- Event channel
- Firmware update in the field
- I/O and trigger control
- Image chunk data
- PTP (IEEE 1588 Precision Time Protocol)
- Stream hold
- Temperature monitoring
- ToE (trigger over Ethernet, action commands)
- User sets

## Technical drawing

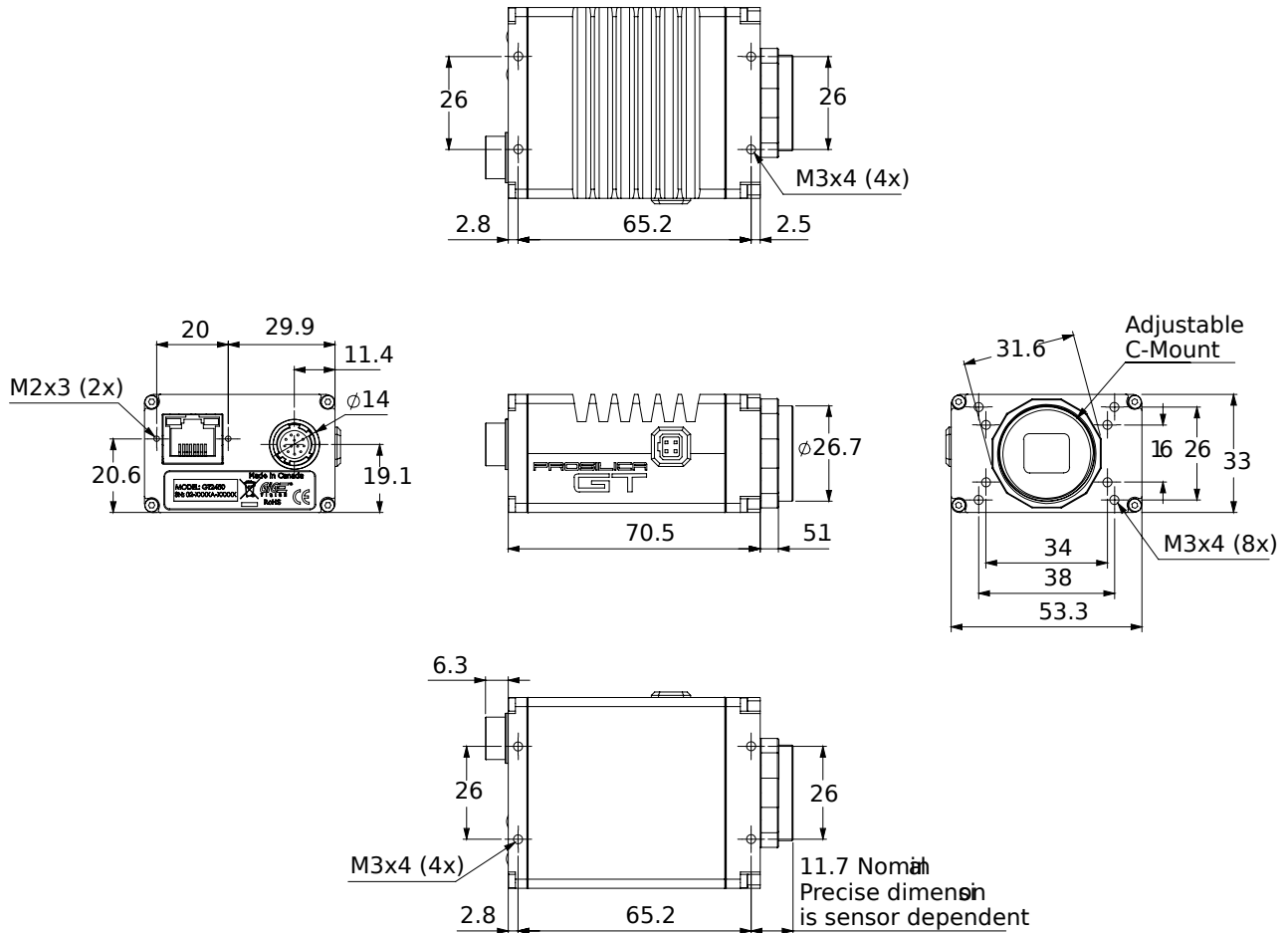

## Applications

Prosilica GT1600 is ideal for a wide range of applications including:

- Outdoor imaging
- Traffic imaging and Intelligent Traffic Systems
- Public security and surveillance
- Industrial inspection
- Machine vision
- Military and space applications