

Prosilica GC 2450



- GigE Vision interface
- Rugged housing
- IEEE 1588 PTP
- Auto iris

Compact performance

Prosilica GC - Ultra-compact GigE Vision camera

Prosilica GC 2450 with Sony ICX625 runs 15.0 frames per second at 5.0 MP resolution.

The Prosilica GC is a GigE camera with an ultra-compact, lightweight housing, fast frame rates, and auto-iris control. It offers a large choice of CCD and CMOS sensors up to 5 Megapixels and fits a wide range of applications.

Easy software integration with [Allied Vision's Vimba Suite](#) and compatibility to the most popular third party image-processing libraries.

See the [Modular Concept](#) for lens mount, housing variants, optical filters, case design, and other modular options. See the [Customization and OEM Solutions webpage](#) for additional options.

Specifications

Prosilica GC 2450	
Interface	IEEE 802.3 1000baseT
Resolution	2448 (H) × 2050 (V)
Sensor	Sony ICX625
Sensor type	CCD Progressive
Shutter mode	Global shutter
Sensor size	Type 2/3
Pixel size	3.45 μm × 3.45 μm
Lens mount (default)	C-Mount
Max. frame rate at full resolution	15 fps

Prosilica GC 2450	
ADC	12 Bit
Image buffer (RAM)	64 MByte
Imaging performance	
Imaging performance data is based on the evaluation methods in the EMVA 1288 Release 3.1 standard for characterization of image sensors and cameras. Measurements are typical values for monochrome models measured at full resolution without optical filter. Contact Sales or AE for more information.	
Quantum efficiency at 529 nm	54 %
Temporal dark noise	10.7 e ⁻
Saturation capacity	3300 e ⁻
Dynamic range	49.3 dB
Absolute sensitivity threshold	11.2 e ⁻
Output	
Bit depth	8/12 Bit
Monochrome pixel formats	Mono8, Mono12, Mono12Packed
RGB color pixel formats	RGB8Packed, BGR8Packed
Raw pixel formats	BayerRG8, BayerRG12, BayerGR12Packed
General purpose inputs/outputs (GPIOs)	
TTL I/Os	1 input, 1 output
Opto-isolated I/Os	1 input, 1 output
RS232	1
Operating conditions/dimensions	
Operating temperature	0 °C to +40 °C ambient (without condensation)
Power requirements (DC)	5 to 25 VDC
Power consumption	3.8 W at 12 VDC
Mass	106 g
Body dimensions (L × W × H in mm)	59 × 46 × 33 (including connectors)
Regulations	CE: 2014/30/EU (EMC), 2011/65/EU, including amendment 2015/863/EU (RoHS); FCC Class A; CAN ICES-003

Quantum efficiency

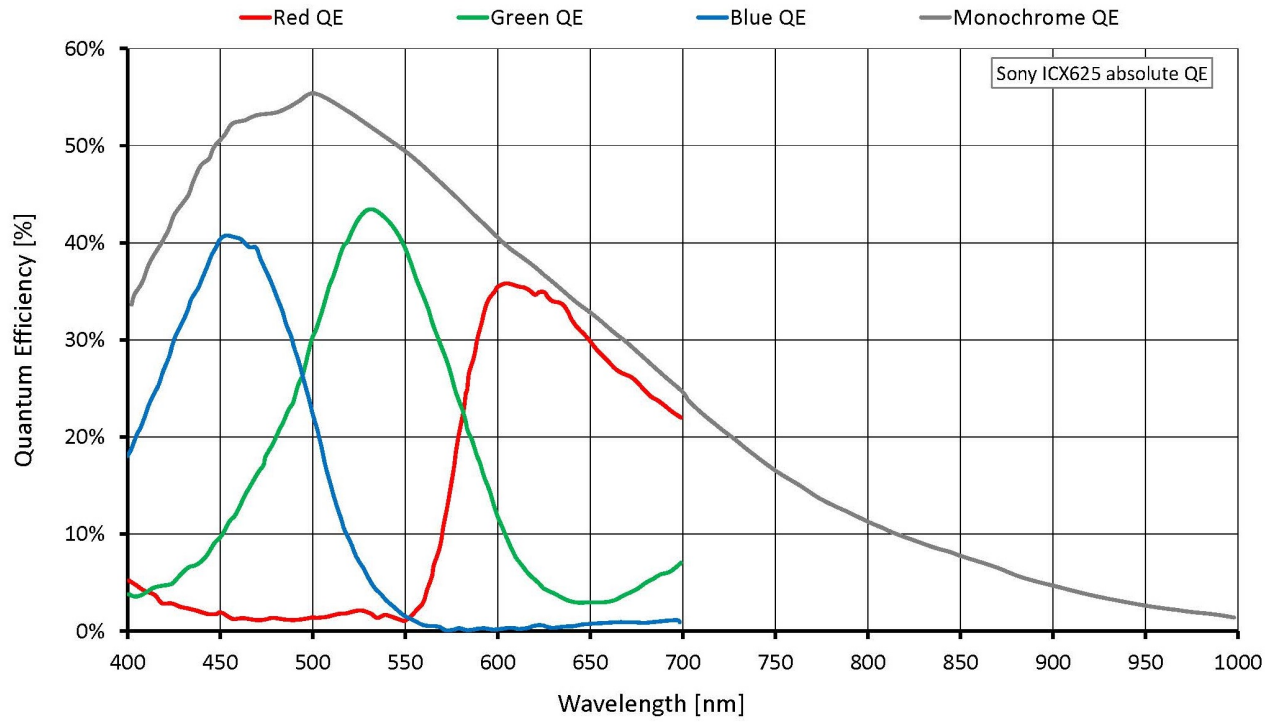

Features

Image control: Auto

- Auto exposure
- Auto gain
- Auto white balance (color models)

Image control: Other

- Binning
- Black level
- Color transformation (incl. hue, saturation; color models)
- Gamma
- LUT (look-up table)

- ROI (region of interest)

Camera control

- Acquisition frame rate
- Auto iris
- Bandwidth control
- Event channel
- Firmware update in the field
- I/O and trigger control
- Image chunk data
- PTP (IEEE 1588 Precision Time Protocol)
- Stream hold
- Temperature monitoring
- User sets

Technical drawing

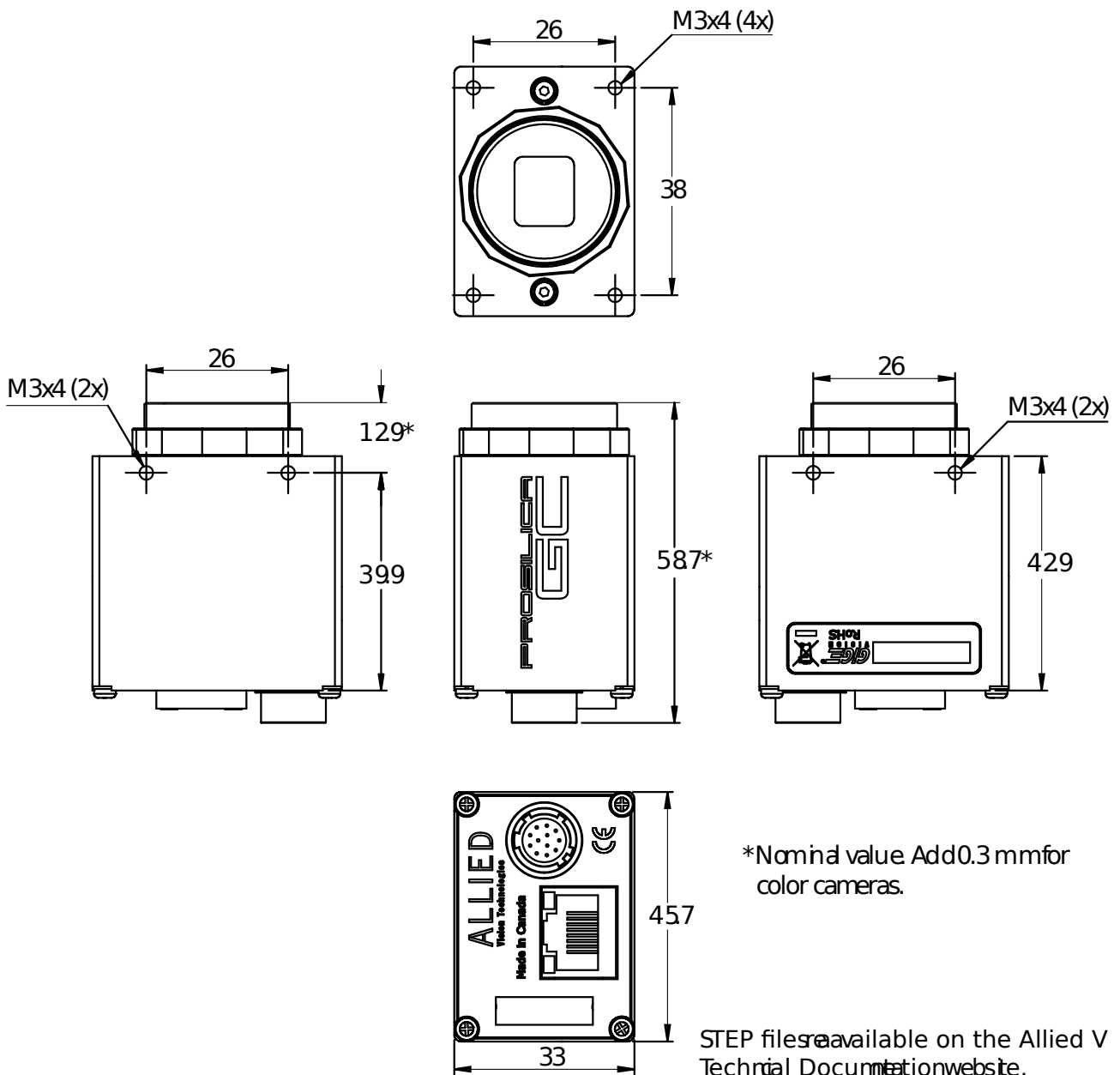

Applications

Prosilica GC2450 is ideal for a wide range of applications including:

- High-resolution industrial inspection
- LCD panel inspection
- Machine vision



- 3D metrology
- Public security
- Surveillance
- Traffic imaging/Intelligent Traffic Systems
- Embedded systems
- OEM applications