



Manta

G-282

- PoE option
- IEEE 1588 PTP
- Trigger over Ethernet
- Auto iris
- Sensor taps
- Angled head option
- Board level option

Simplify your setup of multi-camera applications

Modular machine vision camera with GigE Vision interface

Manta G-282 with Sony ICX687 runs 30.0 frames per second at 2.8 MP resolution.

Manta is Allied Vision's most versatile GigE Vision camera series. It provides the largest choice of image sensors and its advanced feature set simplifies the setup of multi-camera applications. With its modular hardware concept, Manta offers nearly endless configuration possibilities to adapt the camera to your application.

Easy software integration with Allied Vision's [Vimba Suite](#) and compatibility to the most popular [third party image-processing libraries](#).

See the [Modular Concept](#) for lens mount, housing variants, optical filters, case design, and other modular options. See the [Customization and OEM Solutions](#) webpage for additional options.

Specifications

Manta G-282	
Interface	IEEE 802.3 1000BASE-T, IEEE 802.3af (PoE) optional
Resolution	1936 (H) × 1458 (V)
Sensor	Sony ICX687
Sensor type	CCD Progressive
Shutter mode	Global shutter
Sensor size	Type 1/1.8

Manta G-282

Pixel size	3.69 μm \times 3.69 μm
Lens mounts (available)	C-Mount, CS-Mount
Max. frame rate at full resolution	30 fps
ADC	12 Bit
Image buffer (RAM)	128 MByte

Imaging performance

Imaging performance data is based on the evaluation methods in the EMVA 1288 Release 3.1 standard for characterization of image sensors and cameras. Measurements are typical values for monochrome models measured at full resolution without optical filter. Contact Sales or AE for more information.

Quantum efficiency at 529 nm	62 %
Temporal dark noise	10.8 e^-
Saturation capacity	10300 e^-
Dynamic range	59.2 dB
Absolute sensitivity threshold	11.3 e^-

Output

Bit depth	8/12 Bit
Monochrome pixel formats	Mono8, Mono12Packed, Mono12
YUV color pixel formats	YUV411Packed, YUV422Packed, YUV444Packed
RGB color pixel formats	RGB8Packed, BGR8Packed
Raw pixel formats	BayerRG8, BayerRG12Packed, BayerRG12

General purpose inputs/outputs (GPIOs)

Opto-isolated I/Os	2 inputs, 2 outputs
RS232	1

Operating conditions/dimensions

Operating temperature	+5 $^{\circ}\text{C}$ to +45 $^{\circ}\text{C}$ ambient (without condensation)
Power requirements (DC)	8 to 30 VDC AUX or IEEE 802.3af PoE
Power consumption	External power: 3.5 W at 12 VDC Power over Ethernet: 4.1 W
Mass	190 g; 200 g (PoE)
Body dimensions (L \times W \times H in mm)	86.4 \times 44 \times 29 (including connectors)

Manta G-282

Regulations

CE: 2014/30/EU (EMC), 2011/65/EU, including amendment 2015/863/EU (RoHS); FCC Class B; CAN ICES-3 (B)

Quantum efficiency

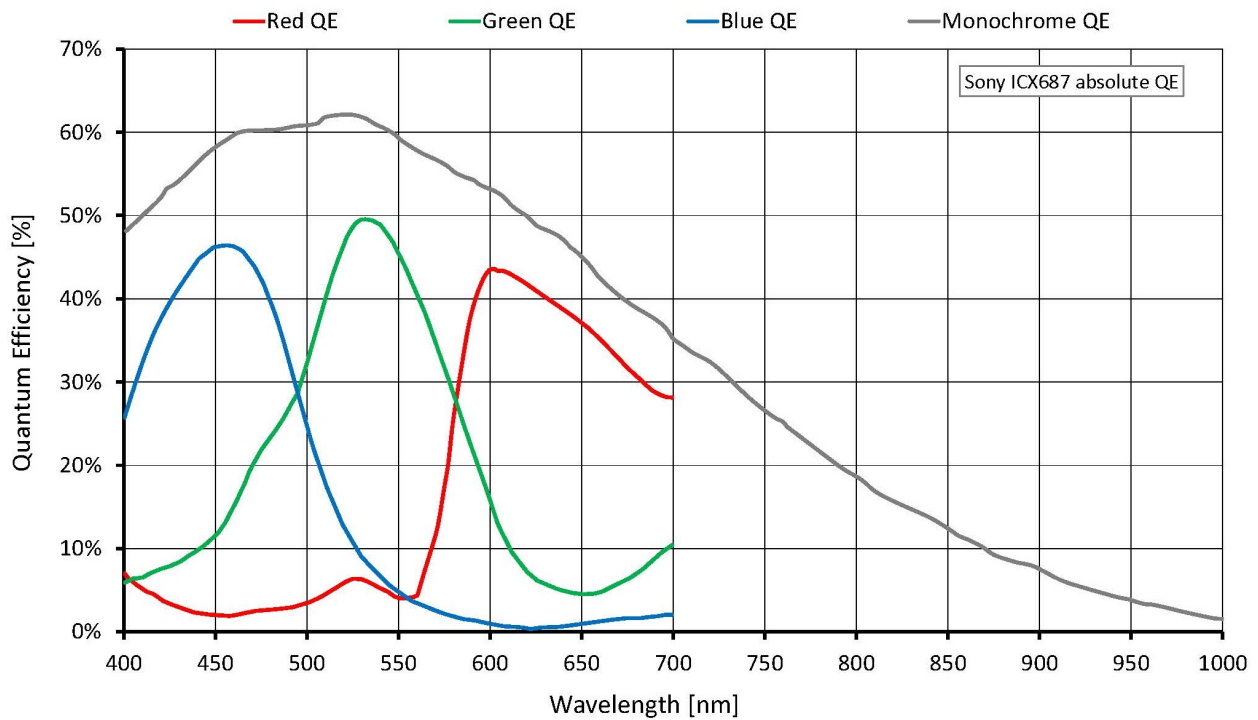

Features

Image control: Auto

- Auto exposure
- Auto gain
- Auto white balance (color models)

Image control: Other

- Binning
- Black level

- Color transformation (incl. hue, saturation; color models)
- Decimation
- Gamma
- LUT (look-up table)
- ROI (region of interest)

Camera control

- Acquisition frame rate
- Auto iris
- Bandwidth control
- Event channel
- Firmware update in the field
- I/O and trigger control
- Image chunk data
- PTP (IEEE 1588 Precision Time Protocol)
- Sensor taps
- Stream hold
- Temperature monitoring
- ToE (trigger over Ethernet, action commands)
- User sets

Technical drawing

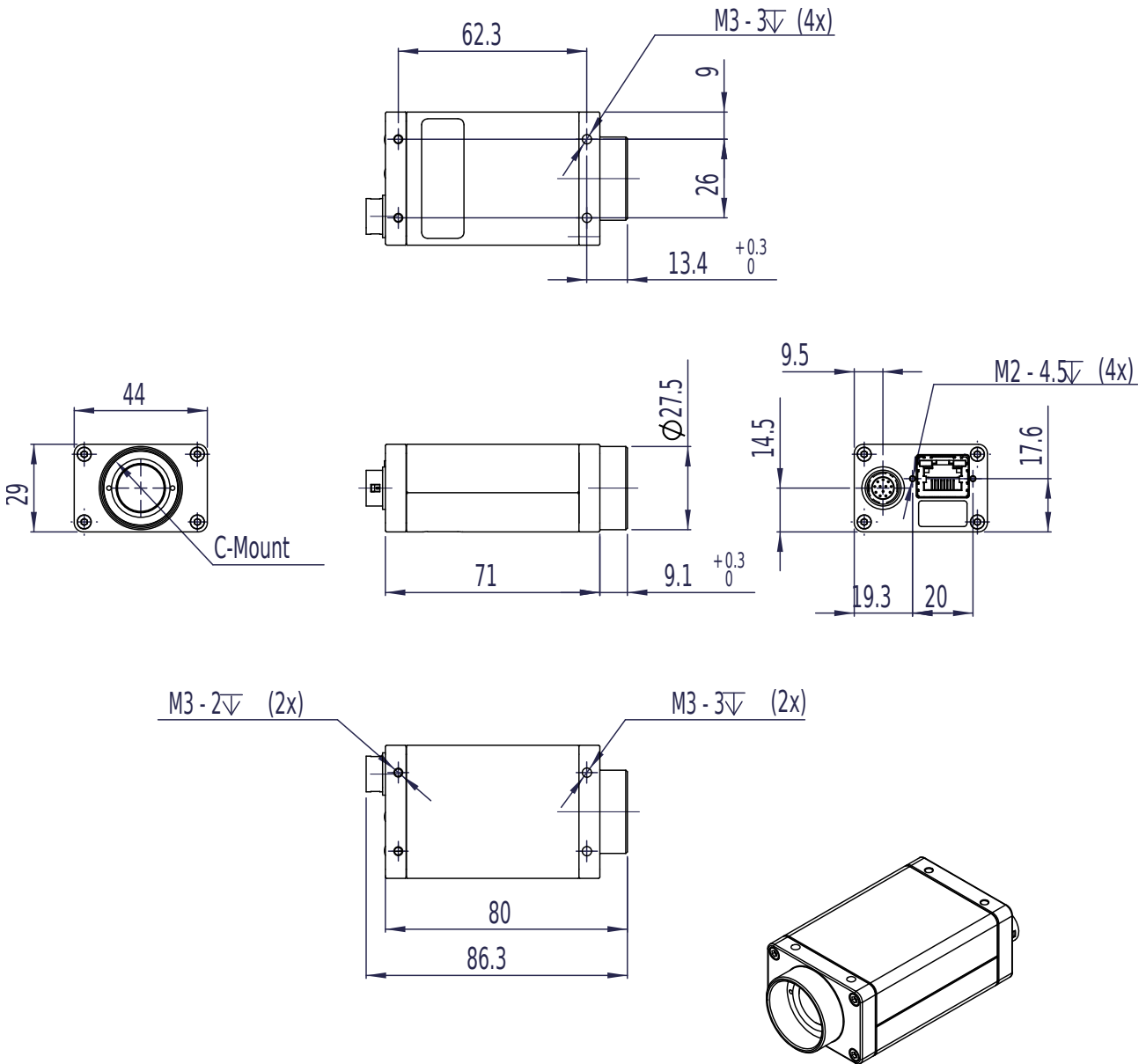

Applications

Manta G-282 is ideal for a wide range of applications including:

- Multimedia and entertainment
- Machine vision



- Security and surveillance
- Metrology and inspection systems
- Industrial image processing