



- PoE option
- IEEE 1588 PTP
- Trigger over Ethernet
- Auto iris
- Angled head option
- Board level option

Simplify your setup of multi-camera applications

Modular machine vision camera with GigE Vision interface

Manta G-1620 with Sony IMX542 runs 7.4 frames per second at 16.2 MP resolution.

Manta is Allied Vision's most versatile GigE Vision camera series. It provides the largest choice of image sensors and its advanced feature set simplifies the setup of multi-camera applications. With its modular hardware concept, Manta offers nearly endless configuration possibilities to adapt the camera to your application.

Easy software integration with Allied Vision's **Vimba Suite** and compatibility to the most popular **third party image-processing libraries**.

See the **Modular Concept** for lens mount, housing variants, optical filters, case design, and other modular options. See the **Customization and OEM Solutions** webpage for additional options.

Specifications

Manta G-1620	
Interface	IEEE 802.3 1000BASE-T, IEEE 802.3af (PoE) optional
Resolution	5328 (H) × 3040 (V)
Spectral range	300 to 1100 nm
Sensor	Sony IMX542
Sensor type	CMOS
Shutter mode	Global shutter
Sensor size	Type 1.1

Manta G-1620	
Pixel size	2.74 μm \times 2.74 μm
Lens mounts (available)	C-Mount, CS-Mount
Max. frame rate at full resolution	7.4 fps
ADC	12 Bit
Image buffer (RAM)	128 MByte
Imaging performance	
Imaging performance data is based on the evaluation methods in the EMVA 1288 Release 3.1 standard for characterization of image sensors and cameras. Measurements are typical values for monochrome models measured at full resolution without optical filter. Contact Sales or AE for more information.	
Quantum efficiency at 529 nm	69 %
Temporal dark noise	2.2 e ⁻
Saturation capacity	9500 e ⁻
Dynamic range	70.7 dB
Absolute sensitivity threshold	2.8 e ⁻
Output	
Bit depth	8/12 Bit
Monochrome pixel formats	Mono8, Mono12Packed, Mono12
YUV color pixel formats	YUV411Packed, YUV422Packed, YUV444Packed
RGB color pixel formats	RGB8Packed, BGR8Packed
Raw pixel formats	BayerRG8, BayerRG12, BayerRG12Packed
General purpose inputs/outputs (GPIOs)	
Opto-isolated I/Os	2 inputs, 2 outputs
RS232	1
Operating conditions/dimensions	
Operating temperature	+5 °C to +45 °C ambient (without condensation)
Power requirements (DC)	8 to 30 VDC AUX or IEEE 802.3af PoE
Power consumption	External power: 3.3 W at 12 VDC Power over Ethernet: 3.9 W
Mass	190 g; 200 g (PoE)
Body dimensions (L \times W \times H in mm)	86.3 \times 44 \times 29 (including connectors)

Manta G-1620

Regulations

CE: 2014/30/EU (EMC), 2011/65/EU, including amendment 2015/863/EU (RoHS); FCC Class B; CAN ICES-3 (B)

Quantum efficiency

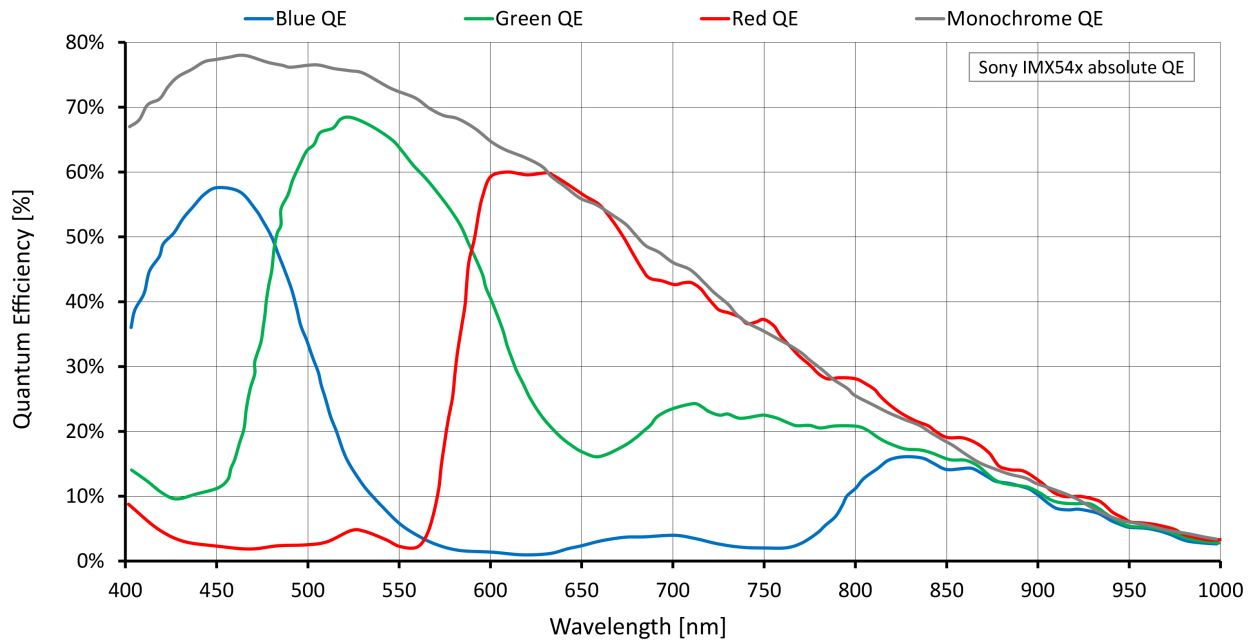

Features

Image control: Auto

- Auto exposure
- Auto gain
- Auto white balance (color models)

Image control: Other

- Binning
- Black level
- Color transformation (incl. hue, saturation; color models)

- Decimation
- DPC (defect pixel correction)
- Gamma
- LUT (look-up table)
- Reverse X/Y
- ROI (region of interest)

Camera control

- Acquisition frame rate
- Auto iris
- Bandwidth control
- Event channel
- Firmware update in the field
- I/O and trigger control
- Image chunk data
- PTP (IEEE 1588 Precision Time Protocol)
- Stream hold
- Temperature monitoring
- ToE (trigger over Ethernet, action commands)
- User sets

Technical drawing

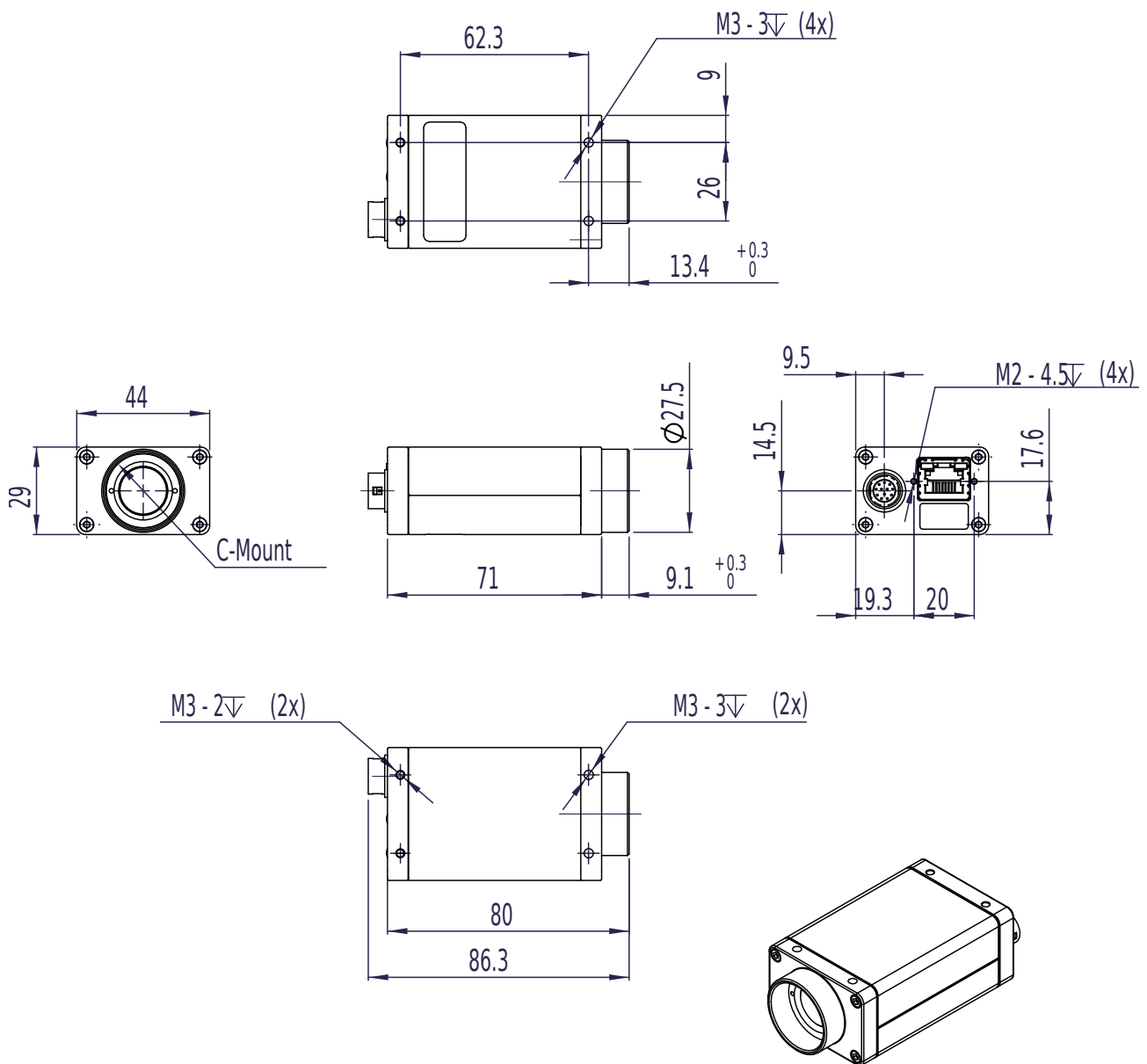

Applications

Manta G-1620 is ideal for a wide range of applications including:

- Machine Vision
- Broadcast analysis requiring Full HD such as sports analytics



- Industrial inspection
- Security and surveillance
- Intelligent traffic solutions (ITS) including traffic monitoring, speed enforcement, and toll collection
- Low light or high sensitivity conditions
- Outdoor applications with dynamic lighting situations