



# Goldeye

## G-032 TEC1

- GigE Vision InGaAs camera
- VGA resolution
- Power over Ethernet
- Compact industrial design
- No fan
- High dynamic range

See the invisible

## Short-wave infrared (SWIR) cameras with InGaAs sensor technology

Goldeye G-032 TEC1 with InGaAs FPA  $636 \times 508$  runs 100.0 frames per second at 0.3 MP resolution.

Goldeye cameras are equipped with InGaAs sensor technology making them sensitive in the short wave infrared spectrum ranging from 900 nm to 1,700 nm. Some models have extended sensitivity in the visible spectrum down to 400 nm. All Goldeye SWIR cameras can be operated at very high frame rates and capture outstanding low-noise images. They are the perfect choice for industrial and scientific applications beyond the visible spectrum. All Goldeye models are available with either a Camera Link or a GigE Vision interface.

Easy software integration with **Allied Vision's Vimba Suite** and compatibility to the most popular third party image-processing libraries.

**AcquireControl** adds extensive image analysis functions, such as:

- Pseudo color LUT with several color profiles
- Auto contrast
- Auto brightness
- Analyze multiple regions (rectangular, circle) within the image
- Real-time statistics and histogram display

The **Modular Concept** offers various options for lens mount, housing variants, optical filters, case design, and more. See the **Customization and OEM Solutions webpage** for additional options.

## Specifications

<b>Goldeye G-032 TEC1</b>	
Interface	IEEE 802.3 1000BASE-T, IEEE 802.3af (PoE)
Resolution	636 (H) × 508 (V)
Spectral range	900 nm to 1700 nm
Sensor	InGaAs FPA 636 × 508
Sensor type	InGaAs
Sensor size	No standard size
Pixel size	25 μm × 25 μm
Lens mounts (available)	C-Mount
Max. frame rate at full resolution	100 fps
ADC	14 Bit
Image buffer (RAM)	256 MByte
Cooling temperature	+5 °C, +20 °C (default and calibrated), +35 °C, +50 °C, or user-configurable
Dark current	380 ke <sup>-</sup> /s (at +20 °C FPA Temperature)
Temporal dark noise	400 e <sup>-</sup> (Gain0), 170 e <sup>-</sup> (Gain1)
Saturation capacity	1.9 Me <sup>-</sup> (Gain0), 39 ke <sup>-</sup> (Gain1)
Dynamic range	73 dB (Gain0), 47 dB (Gain1)
<b>Output</b>	
Bit depth	8 - 14 Bit
Monochrome pixel formats	Mono8, Mono12, Mono12Packed, Mono14
<b>General purpose inputs/outputs (GPIOs)</b>	
TTL I/Os	LVTTL I/Os: 1 Input, 1 Output
Opto-isolated I/Os	1 Input, 2 Outputs
RS232	115 200 Baud, 8N1 (adjustable)
<b>Operating conditions/dimensions</b>	
Operating temperature	-20 °C to +55 °C (Case)
Power requirements (DC)	10.8 V to 30.0 V or via PoE
Power consumption	10.8 W at 12 VDC; <12.95 W PoE

## Goldeye G-032 TEC1

Mass 370 g (with C-Mount adapter)

Body dimensions (L × W × H in mm) 78 × 55 × 55

Regulations CE: 2014/30/EU (EMC), 2011/65/EU, incl. amendment 2015/863/EU (RoHS); FCC Class B

## Quantum efficiency

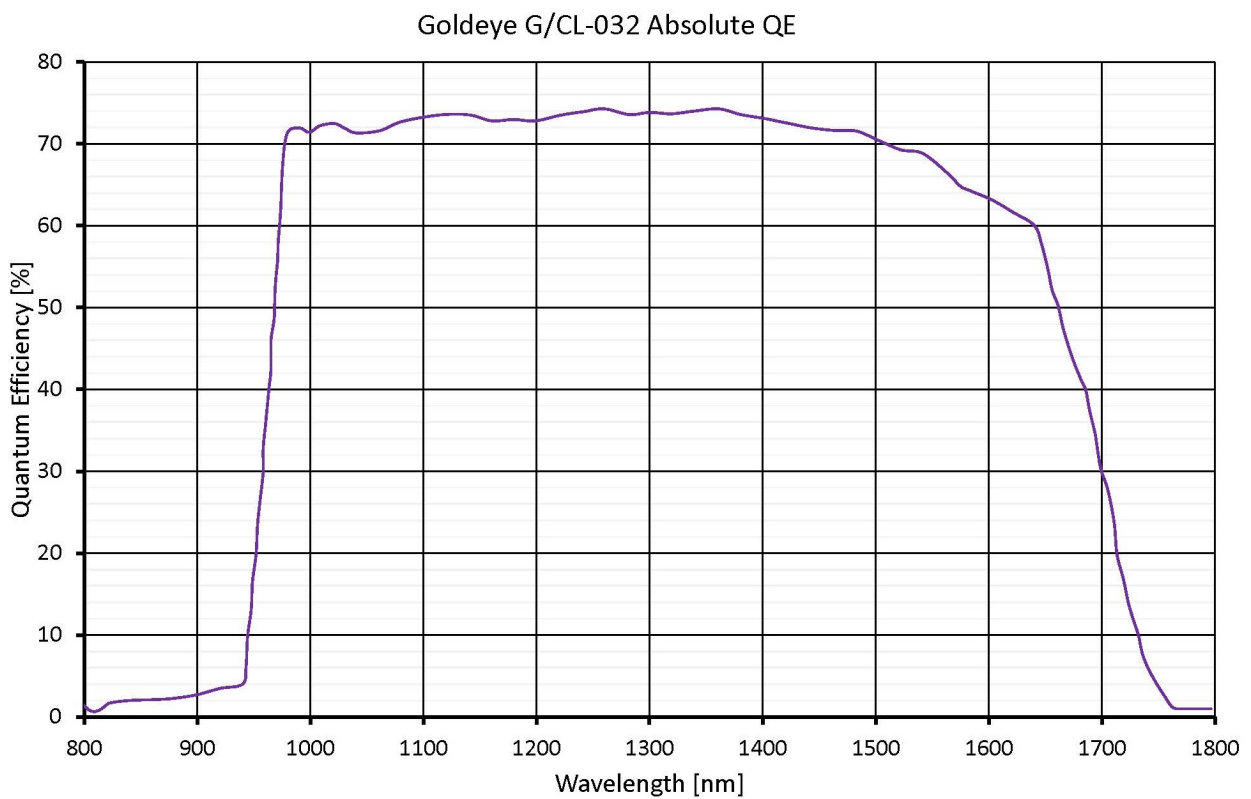

## Features

Image control: Auto

- Auto contrast
- Auto exposure

## Image control: Other

- Background correction
- Binning
- Decimation
- DPC (defect pixel correction)
- LUT (look up table)
- NUC (non-uniformity correction)
- ROI (region of interest)

## Camera control

- Acquisition frame rate
- Bandwidth control
- Event channel
- Firmware update in the field
- I/O and trigger control
- Image chunk data
- Stream hold
- User sets

## Sensor temperature control

- Temperature management by TEC
- Temperature specific events
- Temperature status indicator

## Technical drawing

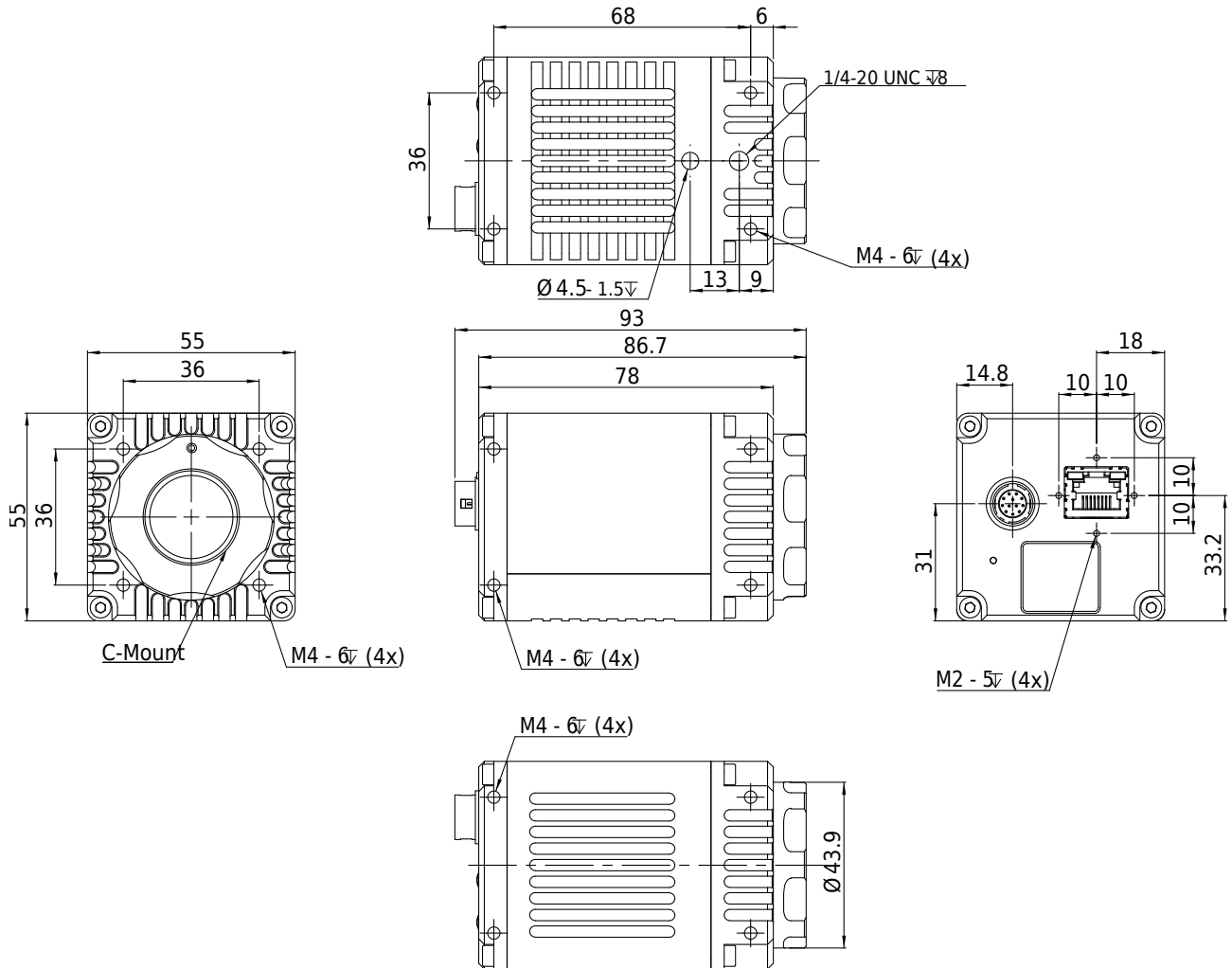

## Applications

Goldeye cameras are very sensitive in the SWIR spectrum. They can be used in an extended operating temperature range. Thanks to temperature stabilization and integrated image correction, Goldeye cameras achieve an outstanding image quality with little noise and a high dynamic range. They are well-suited for many typical SWIR applications in various industry branches:

- Semiconductor industry: solar cell and chip inspection
- Recycling industry: plastics sorting
- Medical imaging, sciences: hyper- and multi-spectral imaging, microscopy, optical coherence tomography (OCT)

- Metal and glass industry: thermal imaging of hot objects (250 °C to 800 °C)
- Agriculture industry: airborne remote sensing
- Printing industry: banknote inspection
- Electronics industry: laser beam profiling
- Surveillance and security: vision enhancement (for example, seeing through fog)

**White Paper** To learn more about typical application fields for SWIR cameras, download our White Paper: [Seeing beyond the visible – short-wave infrared \(SWIR\) cameras offer new application fields in machine vision](#)